

3000 Series

3012SI

Spark Ignited Gas Engine

240 kWm at 1500 rpm
264 kWm at 1800 rpm

Designed in advance of today's uncompromising demands within the gas power generation industry, the Perkins 3000 Series family of 8 and 12 cylinder spark ignition gas engines offers superior performance, dependability and reliability.

The 3012SI is a naturally aspirated 12 cylinder vee-form engine, designed for operation on a wide range of gases including natural, LPG, landfill and digester gases. The internationally proven durability and reliability, combined with exceptional thermal efficiency and reduced whole life costs, make selection of the Perkins 3000 Series engine as prime mover the obvious choice. The 3000 Series spark ignited gas engine can be supplied to suit customer requirements as an Electro Unit for power generation or Cogen Unit specification for combined heat and power (cogeneration) operation.

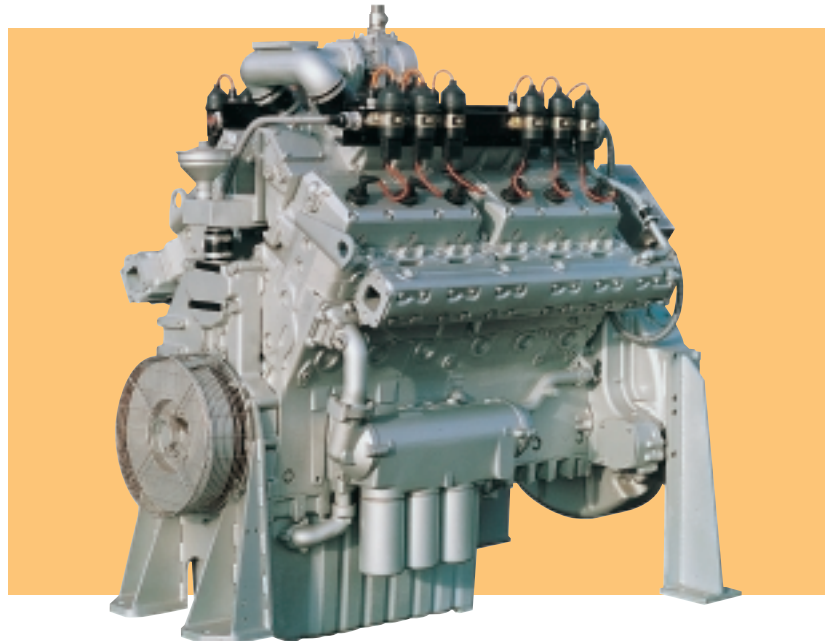

Economic power

- The modern design of the 3000 Series incorporates the latest development and engineering techniques, resulting in excellent durability, economical whole life costs and reliability.

Efficient power

- Designed for maximum thermal efficiency, the 3012SI offers compact, high power to weight ratio, an economical solution to power and heat requirements.
- High commonality of components with other engines in the 3000 Series family offers reduced stocking and inventory levels.

Reliable power

- The high level of product serviceability and ease of maintenance maintain optimum availability.
- Total after-sales service, backed by Perkins' world-wide distributor/dealer network.

Engine Speed rev/min	Type of Operation	Gross Engine Power			
		kWe – Natural Gas*	kWm – Natural Gas*	kWe – LPG (Propane)*	kWm – LPG (Propane)*
1500	Continuous Operation Power	228	240	205	216
1800	Continuous Operation Power	251	264	N/A	N/A

*A catalyst will be required to comply with TA Luft emission regulations

The above ratings represent the engine performance capabilities in accordance within ISO 3046 at reference conditions equivalent to those specified in ISO 3046/1. Electrical ratings are based on average alternator efficiency at a unity power factor based on natural gas having a lower calorific value of 34.71 MJ/m³.

Please consult your local Perkins distributor/dealer or Perkins Engines Company Limited for derating calculations for ambient conditions or use of gaseous fuels other than British natural gas.

Continuous Operation Power – A 'true' Baseload rating as defined in ISO 8528 as COP.

Standard Gas Engine Specification

Core engine

- Cast high-grade iron cylinder block
- Dry slip fit type liners in centrifugally cast iron, plateau honed for quick ring bedding and excellent oil control
- Forged steel crankshaft – nitride hardened
- Twin high mounted camshafts
- High grade cast iron cylinder heads, with four valves per cylinder
- Crankshaft driven gear train for camshaft
- Gallery-cooled aluminium alloy pistons with three-ring packs
- Forged steel split cap connecting rods with 4 bolt fixing

Gas/Ignition system

- Air/fuel mixer with mixture adjustment screw. Zero pressure regulator supplied loose
- Fairbanks Morse IQ 700 ignition system and wiring harness
- Individual cylinder ignition coils

Lubrication system

- Gear driven lubricating oil pump
- Spin on type replaceable lubricating oil filters
- Shell and tube type oil cooler, jacket water-cooled
- Crankcase vented to atmosphere, *closed circuit on Cogen Units*

Cooling system

- Thermostatically-controlled system
- Gear-driven circulating pump †

Air intake system

- Medium duty paper element air filter with restriction indicator

Exhaust system

- Cast iron water-cooled exhaust manifolds
- Horizontal exhaust outlets

Governing system

- Electronic governing system, conforming to ISO 8528 Part 5 Class G2

Electrical system

- 24 Volt electric starter motor
- 24 Volt battery-charging alternator †

Drive system

- Cast iron flywheel housing SAE 0 and flywheel SAE J620 Size 18
- Viscous type torsional vibration damper

Engine protection system

- 24 Volt high coolant temperature and low oil pressure switches

Engine mountings

- Front mounting feet

Painting

- Commercial primer finish

Packing/Preservation

- All engines are preserved after test running, shrink wrapped and suitable for containerised shipment

† Not supplied on Cogen Unit

Technical Data

Number of cylinders	12
Cylinder arrangement	60° Vee
Cycle	4-stroke
Induction system	Naturally aspirated
Combustion system	Spark ignition
Cooling system	Water cooled
Displacement	26.10 litres
Bore and stroke	135 mm x 152 mm
Compression ratio	12.0:1 (Natural Gas) 10.0:1 (LPG – Propane)
Direction of rotation	Anti-clockwise, viewed on flywheel
Total lubrication oil capacity	74 litres
Coolant capacity	68 litres
Engine dimensions:	
Total weight (dry)	2045 kg
Length	1549 mm
Width	965 mm
Height	1542 mm

Fuel consumption kJ/kWs		
	1500 rev/min	1800 rev/min
Natural Gas		
100% of COP rating	2.87	2.85
75% of COP rating	3.01	3.08
LPG (Propane)		
100% of COP rating	2.99	N/A
75% of COP rating	3.22	N/A

COP: Continuous Operation Power

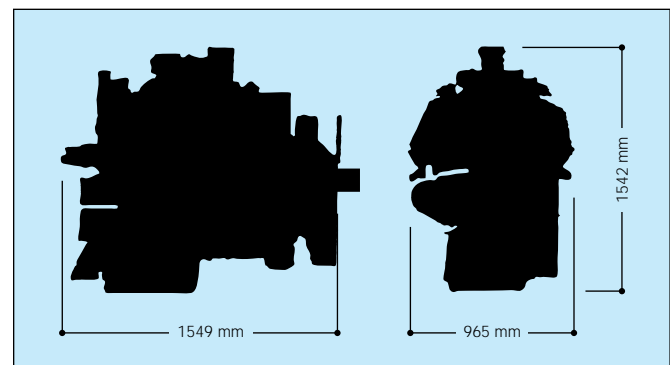

Perkins Engines Company Limited

Tixall Road Stafford ST16 3UB United Kingdom
 Telephone 01785 223141
 Fax 01785 215110
 www.perkins-engines.com

All information given in this leaflet is correct at the time of printing but may be changed subsequently by the company.

Distributed by